



AGRU AMERICA T-LOCK INSTALLATION GUIDE

Agru America T-Lock is a High Density Polyethylene (HDPE) extruded anchoring system designed to provide an embedded attachment for HDPE liner. Agru America T-Lock is designed to embed in any face of new cast-in-place or precast concrete construction and can be fabricated to maneuver around shapes and corners.

Any thickness of HDPE liner can be welded to Agru America T-Lock. If unexpectedly high tensile loads are experienced by the liner, the liner is designed to yield before the T-Lock will yield or pull out of the concrete. The T-Lock Profile is detailed in Figure 1.

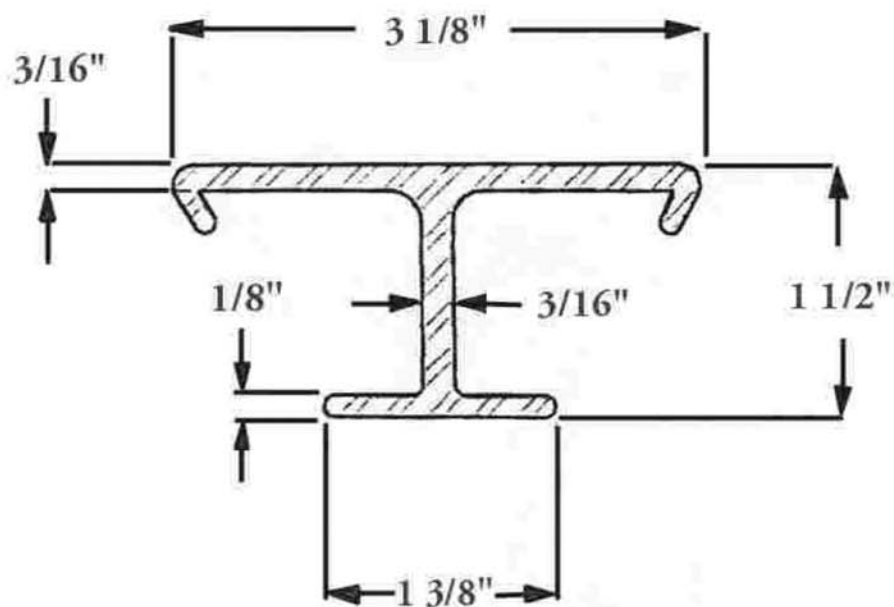

Figure 1- Agru America T-Lock

Attachment of the HDPE Liner to T-Lock is performed by grinding the T-Lock and the HDPE Liner and then extrusion welding the HDPE Liner to the T-Lock.

Proper installation techniques must be observed to ensure a secure embedment of the T-Lock and a sound weld to the HDPE Liner.



T-LOCK INSTALLATION

T-Lock must be cut and butt-welded together to fit corners and shapes. This cutting and welding, if performed correctly, will provide continued support for the HDPE Liner and secure a seal. Corners and “T” connections can be supplied prefabricated.

ATTACHMENT OF T-LOCK TO FORMS

Agru America T-Lock is attached to the inside of a concrete form with finishing nails prior to concrete placement (Figure 2). The finishing nails should be 1 inch or smaller. The nails must be driven flush with the back of the T-Lock to allow for their easy removal when the forms are wrecked. The T-Lock should be attached sufficient points to ensure a flush fitting with the form.

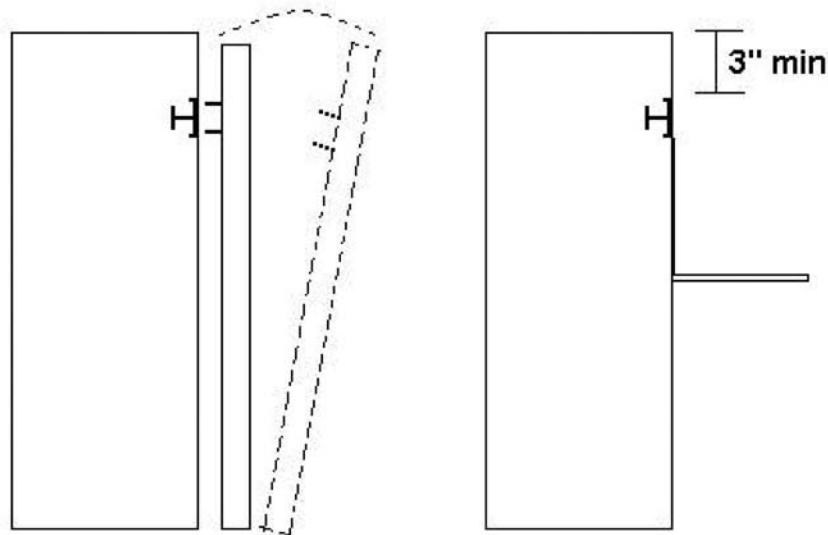

Figure 2

EMBEDMENT OF THE T-LOCK

The concrete surrounding the T-Lock should be vibrated to ensure that there are no void spaces in the concrete adjacent to the T-Lock.

After the concrete has set and the forms are wrecked, the finishing nails can be removed. If concrete gets between the T-Lock and the form, it should be chipped away to reveal the face of the T-Lock. Any sharp edges that are created by the chipping back of the concrete must be beveled to prevent possible cutting or puncturing of the liner.



HEAT FUSION WELDING OF T-LOCK

The recommended method of burr-welding T-Lock is a heat fusion welding method which yields a continuous strip of material. The following is a list of tools and procedures required to perform the heat fusion welding method.

Welding Tools

110 V Leister Triac with Welding Mirror Attachment

-or-

Any Double Sided Butt-Welding Hot Plate

Welding Procedures

1. Cut the ends of the T-Lock to be welded. These cuts should be square and smooth with no nicks or gouges in the surface.
2. Clean ends with a clean cotton cloth to remove dirt, water, grease and other foreign materials.
3. Insert clean and pre-heated welding mirror plate between ends and bring the ends firmly in contact with the mirror plate while achieving an even melt pattern over the cut face of the T-Lock. Allow the ends to heat and soften until a melt bead of approximately 1/8" appears.
4. Remove the mirror plate from between the two pieces of T-Lock and bring the melted ends together. Apply enough pressure to produce a 1/8" roll-back bead.
5. Allow the joint to cool.